

KOHLER®

PERFORMANCE
ENGINEERING

Every part, every component, every system on our engines is guided by Kohler's exclusive Performance Engineering. It's your assurance that every engine we produce will live up to and build upon the worldwide KOHLER® reputation for excellence.



KOHLER® Courage® XT-Series Model Specifications

Engine Type	Four-cycle, single-cylinder, air-cooled, vertical shaft, gasoline, OHV, with cast iron liner.		
Model		XT-6	XT-7
Net Peak Torque @ 2600 rpm	ft lb (Nm)	5.9 (8)	7 (9.5)
Max Net Power @ 3600 rpm	hp (kW)	3.5 (2.6)	4.5 (3.5)
Displacement	cu in (cc)	10.6 (173)	
Bore	in (mm)	2.7 (70)	
Stroke	in (mm)	1.8 (45)	
Compression Ratio		8.5:1	
Dry Weight	lb (kg)	29 (13.1)	
Lubrication		Splash	
Enrichment		Primer	
Starting	U.S. qt (L)	Recoil	
Fuel Capacity	U.S. qt (L)	1.5 (1.4)	
Oil Capacity	U.S. qt (L)	.75 (.7)	
*Dimensions L x W x H	in (mm)	*16.1 x 13.9 x 11.0 (409 x 353 x 278)	**16.1 x 13.9 x 11.0 (409 x 353 x 278)

Preliminary information, subject to change.

Horsepower ratings exceed Society of Automotive Engineers Small Engine Test Code J1940. Actual engine horsepower is lower and affected by, but not limited to, accessories (air cleaner, exhaust, charging, cooling, fuel pump, etc.), application, engine speed and ambient operating conditions (temperature, humidity and altitude). For more information, contact Kohler Co. Engine Engineering.

Kohler reserves the right to change product specifications, designs and equipment without notice and without incurring obligation.

*Length is valve cover to end of blower housing. Width is air cleaner to opposite side. Height is mounting surface to grass screen.

Standard Features

- OHV
- Primer bulb
- Large fuel inlet
- Ergonomic pull handle
- Internally vented carburetor
- Yearly service intervals
- Plated automotive style air filter
- Flywheel ball bearing
- Cast iron liners
- Fixed speed
- Flywheel brake
- Aluminum alloy with cast iron liner
- Extended yellow dipstick
- Forged crankshaft
- Recoil start
- Muffler with international compliant guard
- International symbols
- Electronic ignition

Popular Factory Options

- Manual choke
- Blade brake clutch (BBC)
- CARB Tier III compliance
- Variable speed
- Remote ignition shut-down
- Tethered fuel cap
- Precleaner
- Fuel filter

THE NEW KOHLER® Courage® XT-Series XT-6 and XT-7 Engines



KOHLER®



For more information, contact your KOHLER source of supply
Or call toll-free in the U.S. and Canada 1-800-544-2444.

Kohler Co., Kohler, Wisconsin 53044 Tel 920-457-4441 Fax 920-459-1570

KohlerEngines.com

© 2007 by Kohler Co. All rights reserved.

KOHLER®

Relentless Power.
Legendary Performance.

Printed in U.S.A. E-2131 10/07

Made the only way we know. Commercial-grade.

Everything you've come to expect from KOHLER® engines for over 75 years – now available for the walk-behind market. From their cast iron cylinder liner to their heavy-duty forged crankshaft, the new Courage XT-Series engines are tough, reliable and commercial-grade. But while the engines work hard, the consumer doesn't – thanks to a long list of operator features including smooth, ball bearing starts and wide-opening gas fill.



Overhead valve design.

Super-efficient combustion for smooth, powerful performance with lower fuel consumption and cleaner emissions.

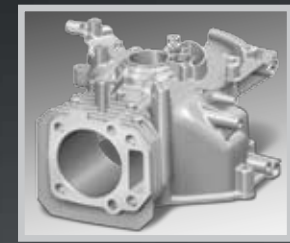

Commercial-grade cast iron cylinder liner.

For extra durability and longer engine life. And while others make cast iron liners optional, we make them standard.



Heavy-duty forged crankshaft.

Forged – not cast – for superior tensile strength and less chance for failure. Made tougher for heavy loads and extra-rough mowing conditions.



Flywheel ball bearing.

Reduced friction and pulling effort for fast, smooth, easy starts and provides extra lubrication for mowing at all angles.



Wide gas tank opening.

Easier filling, less spilling. And simple, easy-to-see fuel-level checks for the consumer. Another KOHLER exclusive.

Emissions:

Certified for both EPA and California emissions standards. Precise air-to-fuel ratio for cleaner combustion with optimum horsepower and torque.

Service:

Backed by more than 13,000 dealers and distributors worldwide.

Warranty:

Two-year limited warranty covering all consumer applications.

KOHLER® COURAGE® ENGINE ARCHITECTURE

3.5 and 4.5 hp verticle shaft engines

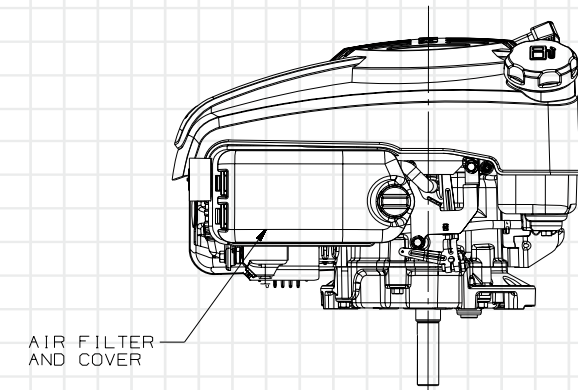
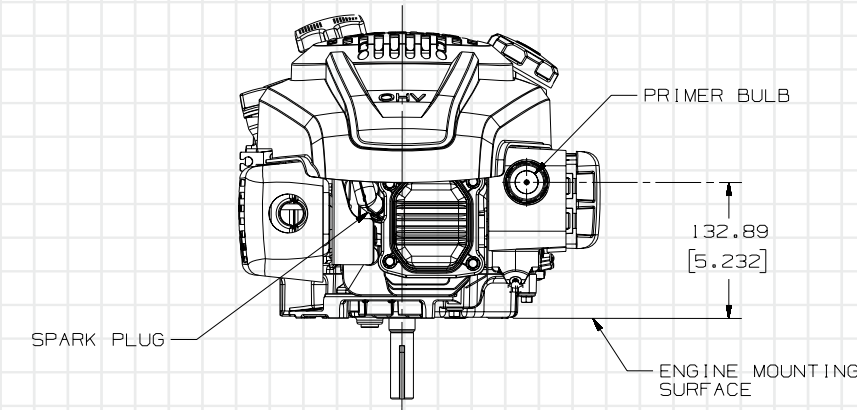
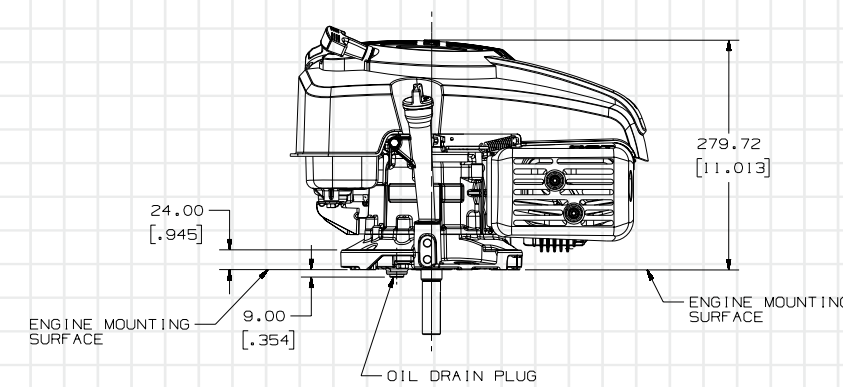

OIL FILL VIEW

TOP VIEW

VALVE COVER VIEW

AIR FILTER VIEW

PTO VIEW

3.5 and 4.5 hp verticle shaft engines

